

**CROWN**  
PEDESTRIAN AND AREA LIGHTING



GARDCO  
LIGHTING



Gardco Lighting is a Philips group brand

**PHILIPS**

# PERFORMANCE MEETS AESTHETICS

The style and form of the Gardco Crown provides a subtle and refined architectural statement. The lower housing crown and canted top enhances the traditional square form with a touch of elegance. The graceful styling of the distinctive yoke is especially appealing in pedestrian scale post-top applications. Crown features proven Gardco Form Ten optical systems, ensuring optimized lamp performance and maximized pole spacings. Moreover, Crown can be configured with the new Philips CosmoPolis™ lamp – a cost-effective, energy-efficient outdoor lighting system – to deliver maximum energy savings and a very pleasing white light.



## High-Performance Optics

Performance is never an issue with Crown, as it features the Gardco Form Ten optical system. Crown accepts five optical systems for a variety of distributions, including four horizontal configurations and a vertical lamp with a sag lens. All optical systems are easily rotatable in 90° increments without tools, eliminating the need for unsightly and costly bullhorns while ensuring maximum efficiency.

## Mounting Options

Crown's distinct look and numerous configurations make it ideal for any application. It can be arm-mounted in single or twin assemblies, and of course wall-mounted if preferred. The configuration that truly distinguishes Crown, however, is its post top mount on the stylish Gardco single plane dual yoke. Architects desire a yoke mounted luminaire that doesn't sacrifice aesthetics, and Crown truly delivers.



#### Energy Savings

Crown is among the first luminaires available with the new energy-efficient, low-cost Philips CosmoPolis™ lighting system. CosmoPolis™ combines a revolutionary new white light ceramic metal halide lamp and an optimized electronic ballast to offer improved visibility, enhanced ambiance, long life and lower power consumption. The result is a system that uses up to 50% less energy and is significantly less expensive than other products while minimizing environmental impacts and CO2 emissions – Green energy without "green" expenses.

#### Quality Construction

Crown combines an exciting, unique form with Gardco's renowned quality of construction. The luminaire features an extruded aluminum housing with solid sides and a die formed aluminum top, as well as a distinctive aluminum crown that is as dynamic as it is durable. Like all Gardco products, Crown is finished in a fade- and abrasion-resistant thermally cured TGIC powdercoat, and all points of entry are fully sealed and gasketed to prevent intrusion from dirt, insects, and other contaminants. It features toolless access to the optical system, ensuring that the rare service call will be quick and easy.



# CROWN

Including Crown with CosmoPolis™ 

**GENERAL DESCRIPTION:** The Gardco Crown luminaires are arm, wall, and post top mount cutoff units for high intensity discharge lamps up to 250 watts. Luminaires feature an extruded aluminum housing with die formed aluminum top, and a distinctive extruded aluminum crown. Post top units utilize the distinct Gardco single plane dual yoke. Luminaires are finished in an TGIC polyester powdercoat. Crown luminaires accept one of five (5) interchangeable and rotatable precision segmented optical systems.

**CUTOFF PERFORMANCE:** Flat glass lens luminaires provide full cutoff performance. Sag lens luminaires provide cutoff performance.

## ORDERING

Example	PREFIX	CONFIGURATION	DISTRIBUTION	WATTAGE	VOLTAGE	FINISH	OPTIONS
	CNA16	1	1	50MH	120	BRP	F
	<b>CNA16</b> 16" Arm Mount	<b>1</b> Single Assembly <b>2</b> Twin @ 180°	<u>Horizontal Lamp</u> <b>1</b> Type I <b>3</b> Type III <b>FM</b> Type IV <b>Q</b> Type V  <u>Vertical Lamp</u> <b>VS</b> <sup>1</sup> Type V	<b>50MH</b> <sup>2,3</sup> <b>70MH</b> <sup>2,3</sup> <b>100MH</b> <sup>2,3</sup> <b>150MH</b> <sup>2,3</sup> <b>175MH</b> <sup>4</sup> <b>200MH</b> <sup>2,3</sup> <b>250MH</b> <sup>5</sup>  <b>175 PSMH</b> <sup>6,8</sup> <b>70HPS</b> <b>100HPS</b> <b>150HPS</b>  <b>60CMPE</b> 200-277V only.	<b>120</b> <b>208</b> <b>240</b> <b>277</b> <b>347</b> <b>480</b>  <b>QUAD</b> <b>200-277</b> 60CMPE only.	<b>BRP</b> Bronze Paint <b>BLP</b> Black Paint <b>WP</b> White Paint <b>NP</b> Natural Aluminum Paint <b>OC</b> Optional Color Paint Specify RAL designation. Ex. OC-RAL7024. <b>SC</b> Special Color Paint Specify. Must supply color chip.	<b>F</b> Fusing In Head <b>LF</b> In-Line/In-Pole Fusing <b>PC</b> Photocontrol and Receptacle Not available with 480V. <b>PCR</b> Photocontrol Receptacle Only <b>POLY</b> Polycarbonate Sag Lens In lieu of flat glass lens. <b>HS</b> Internal Houseside Shield Supplied standard with FM optics. <b>QS</b> Quartz Standby <b>QST</b> Quartz Standby - Timed Delay <b>PTF2</b> <sup>7</sup> Pole Top Fitter (2 <sup>3</sup> / <sub>8</sub> " x 4") <b>PTF3</b> <sup>7</sup> Pole Top Fitter (3" - 3 <sup>1</sup> / <sub>2</sub> ") <b>PTF4</b> <sup>7</sup> Pole Top Fitter (3 <sup>1</sup> / <sub>2</sub> " - 4")

1. Luminaires with Type VS optics are supplied with an acrylic sag lens. Optics require a medium base lamp. 200 W maximum. Not available in 60CMPE.  
2. Medium base lamp.  
3. 200MH and all MH 150 watts and below is pulse start by design.  
4. Utilizes medium base lamp in vertical optics.  
5. Available in horizontal lamp optics only.  
6. Available in vertical lamp optics only.

**60CMPE** 60 Watt CosmoPolis™ high performance electronic ceramic MH lamp and ballast system. 

7. Available with arm mounted luminaires only.

Prior to ordering, consult Submittal Data Sheet on [sitelighting.com](http://sitelighting.com) for the most current information, notes and exclusions.

Gardco Lighting reserves the right to change materials or modify the design of its product without notification as part of the company's continuing product improvement program.

## DIMENSIONS

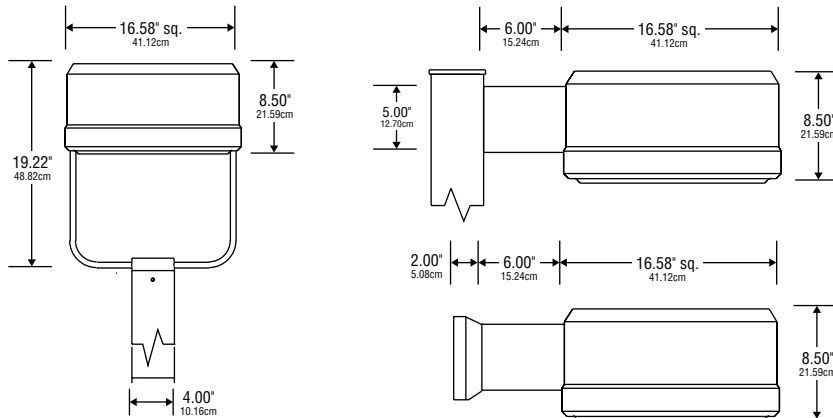

SIZE	EPA'S		WEIGHTS
	SINGLE	TWIN	SINGLE
CNA16	1.41 ft <sup>2</sup>	2.82 ft <sup>2</sup>	33 lbs
	.131 m <sup>2</sup>	.262 m <sup>2</sup>	15.0 kg
CNP16	1.31 ft <sup>2</sup>	N/A	33 lbs
	.122 m <sup>2</sup>		15.0 kg
CNW16	N/A	N/A	35 lbs
			15.9 kg

Gardco Lighting is a Philips group brand

1611 Clovis Barker Road  
San Marcos, TX 78666  
512/753-1000  
800/227-0758  
Fax: 512/753-7855  
[www.sitelighting.com](http://www.sitelighting.com)

